

SXEY-16~54型 (45°背蓋)

d2

Exd IIB

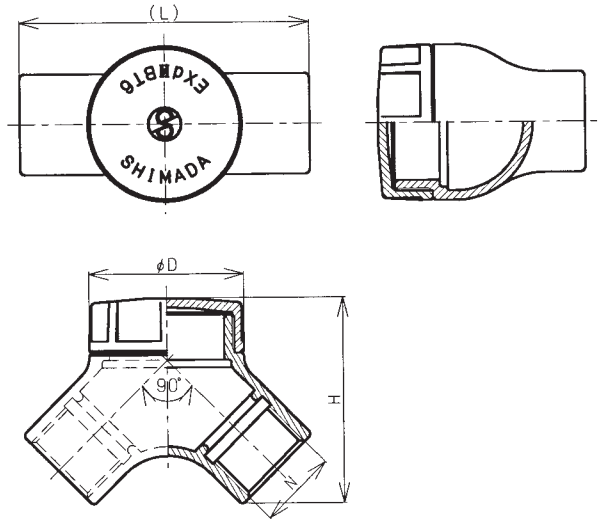

主材質	鑄鉄
表面処理	電着

型式	N	φD	H	(L)	重量(kg)	納期目安
SXEY-16	PF 1/2	65	68.5	89.5	0.6	◎
SXEY-22	PF 3/4	65	74.5	103	0.7	◎
SXEY-28	PF 1	65	87	122	0.8	◎
SXEY-36	PF 1 1/4	85	103	148.5	1.5	◎
SXEY-42	PF 1 1/2	85	113	159	1.8	◎
SXEY-54	PF 2	100	130	190	2.4	◎

SXEYB-16~54型 (45°横蓋)

d2

Exd IIB

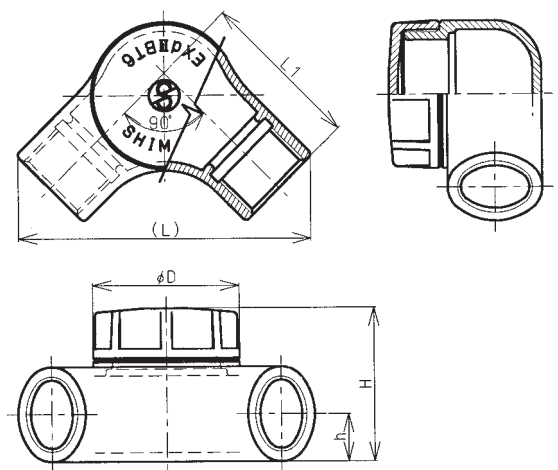

主材質	鑄鉄
表面処理	電着

型式	N	φD	h	H	L1	(L)	重量(kg)	納期目安
SXEYB-16	PF 1/2	65	14.5	55	60	104	0.7	◎
SXEYB-22	PF 3/4	65	17.5	61	65	115	0.8	◎
SXEYB-28	PF 1	65	21	68	72	130	1.0	◎
SXEYB-36	PF 1 1/4	85	26	80	80	148	1.6	◎
SXEYB-42	PF 1 1/2	85	30	89	85	162	1.8	◎
SXEYB-54	PF 2	100	36	102	90	176	2.5	◎

耐圧防爆構造エルボ・チーズ

SXEB-16~54型 (90°背蓋)

d2

Exd II B

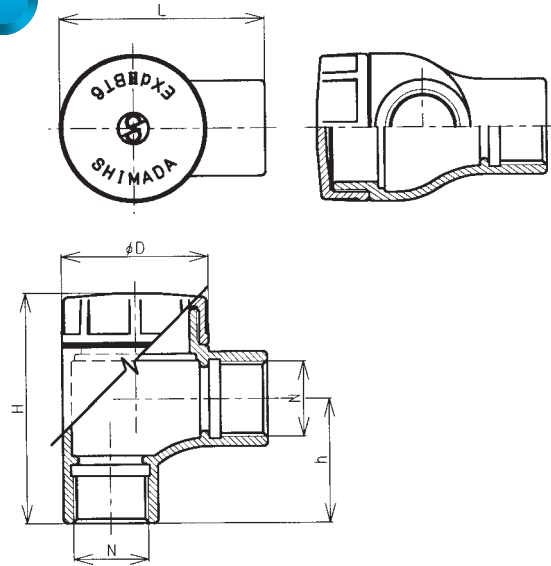

主材質	鋳鉄
表面処理	電着

型式	N	φD	h	H	L	重量(kg)	納期目安
SXEB-16	PF 1/2	65	45.5	86	85	0.7	◎
SXEB-22	PF 3/4	65	50	93.5	85	0.7	◎
SXEB-28	PF 1	65	55	102	91	0.8	◎
SXEB-36	PF 1 1/4	85	66	121	112	1.6	◎
SXEB-42	PF 1 1/2	85	67	127	112	1.8	◎
SXEB-54	PF 2	100	77	144	127	2.5	◎

SXET-16~54型

d2

Exd II B

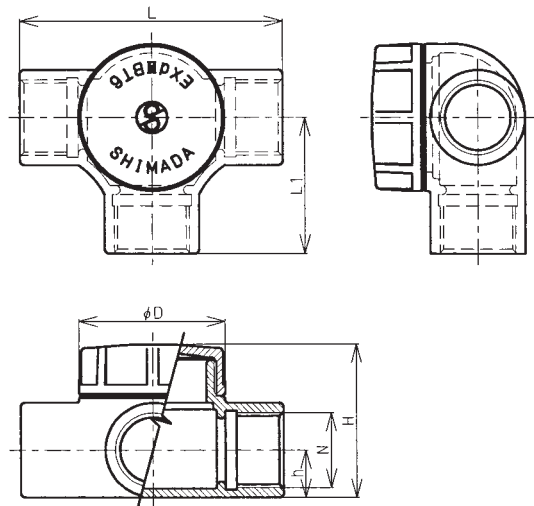

主材質	鋳鉄
表面処理	電着

型式	N	φD	h	H	L1	L	重量(kg)	納期目安
SXET-16	PF 1/2	65	14.5	55	52.5	105	0.7	◎
SXET-22	PF 3/4	65	17.5	61	55	105	0.8	◎
SXET-28	PF 1	65	21	68	60	117	1.0	◎
SXET-36	PF 1 1/4	85	26	81	70	139	1.7	◎
SXET-42	PF 1 1/2	85	30	90	75	139	2.0	◎
SXET-54	PF 2	100	36	103	85	154	2.7	◎