

## SGT-16~70型

d2

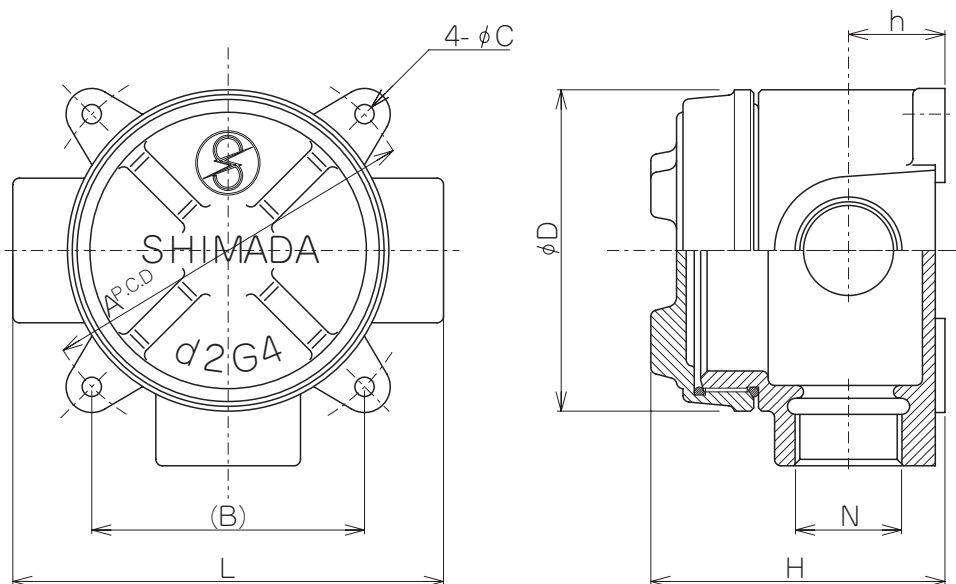
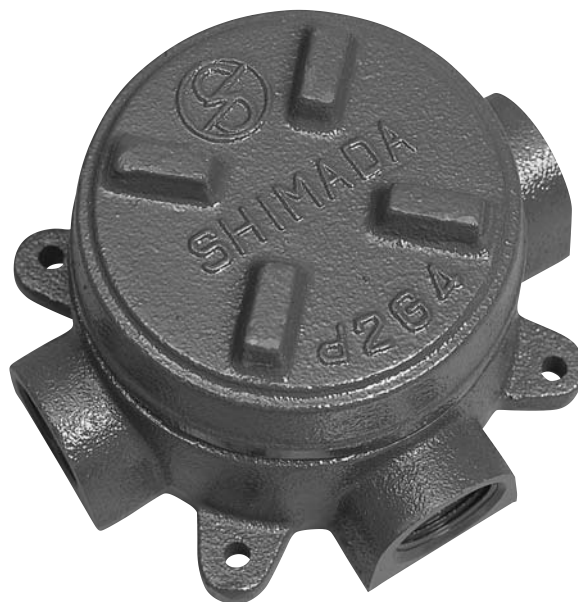

型式	N	A	(B)	φC	φD	h	H	L	重量(kg)	納期目安
SGT-16	PF 1/2	120	85	6	100	21	78	134	1.8	◎
SGT-22	PF 3/4	120	85	6	100	21	78	134	1.8	◎
SGT-28	PF 1	120	85	6	100	30	94	134	2.1	◎
SGT-36	PF 1 1/4	145	103	9	125	33	110	161	4.4	◎
SGT-42	PF 1 1/2	145	103	9	125	40	122	161	3.9	◎
SGT-54	PF 2	180	127	9	160	50	142	196	7.5	◎
SGT-70	PF 2 1/2	190	134	9	160	55	157	210	8.0	◎

主材質	鋳鉄
表面処理	電着

## 耐圧防爆構造ジャンクションボックス

### SGX-16~70型

d2

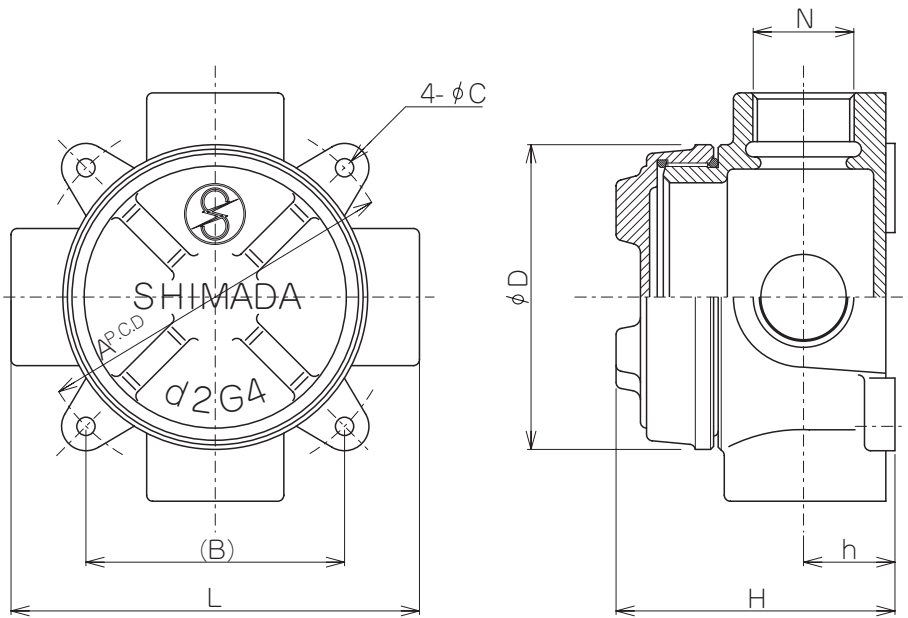

型式	N	A	(B)	φC	φD	h	H	L	重量(kg)	納期目安
SGX-16	PF 1/2	120	85	6	100	21	78	134	1.8	◎
SGX-22	PF 3/4	120	85	6	100	21	78	134	1.8	◎
SGX-28	PF 1	120	85	6	100	30	94	134	2.1	◎
SGX-36	PF 1 1/4	145	103	9	125	33	110	161	4.4	◎
SGX-42	PF 1 1/2	145	103	9	125	40	122	161	3.9	◎
SGX-54	PF 2	180	127	9	160	50	142	196	7.5	◎
SGX-70	PF 2 1/2	190	134	9	160	55	157	210	8.0	◎

主材質	鋳鉄
表面処理	電着

## SGT-16D~70D型

d2

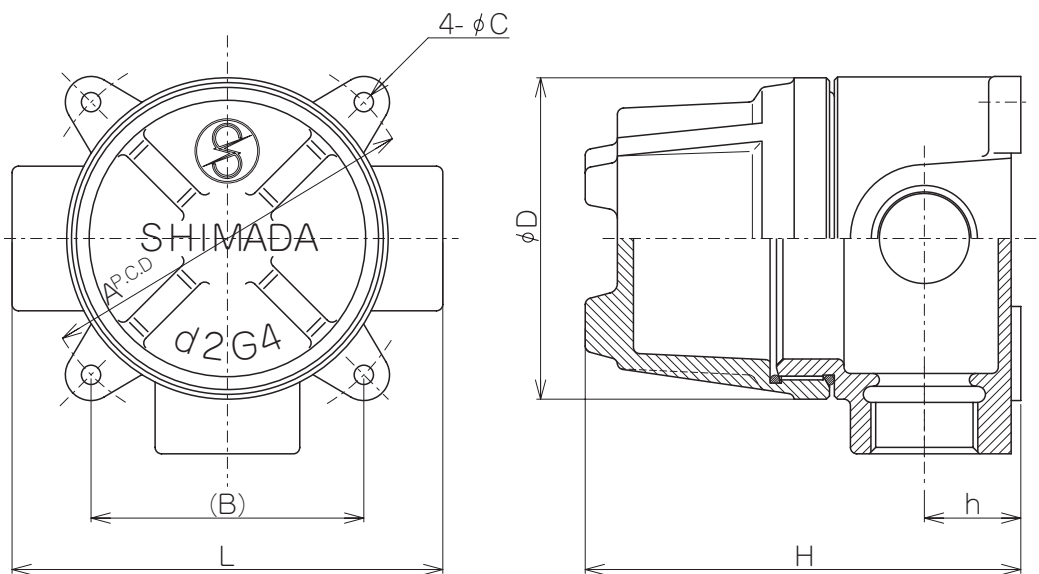

型式	N	A	(B)	φC	φD	h	H	L	重量(kg)	納期目安
SGT-16D	PF 1/2	120	85	6	100	21	120	134	2.1	◎
SGT-22D	PF 3/4	120	85	6	100	21	120	134	2.1	◎
SGT-28D	PF 1	120	85	6	100	30	140	134	2.4	◎
SGT-36D	PF 1 1/4	145	103	9	125	33	160	161	4.7	◎
SGT-42D	PF 1 1/2	145	103	9	125	40	160	161	4.4	◎
SGT-54D	PF 2	180	127	9	160	50	185	196	8.2	◎
SGT-70D	PF 2 1/2	190	134	9	160	55	192	210	8.7	◎

主材質	鋳鉄
表面処理	電着

## 耐圧防爆構造ジャンクションボックス（ドーム型）

### SGX-16D~70D型

d2

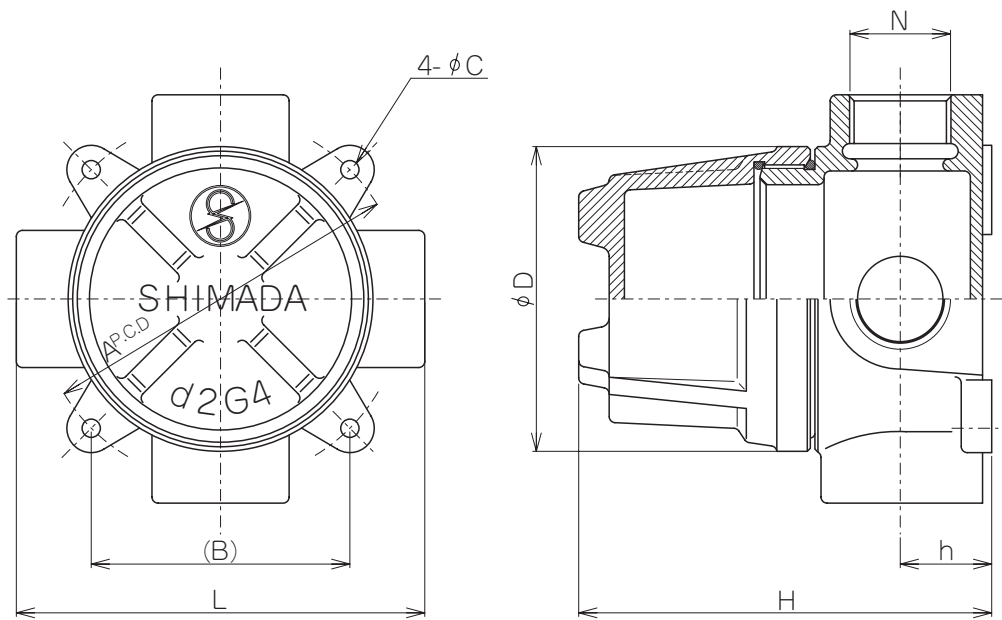

型式	N	A	(B)	φC	φD	h	H	L	重量(kg)	納期目安
SGX-16D	PF 1/2	120	85	6	100	21	120	134	2.1	◎
SGX-22D	PF 3/4	120	85	6	100	21	120	134	2.1	◎
SGX-28D	PF 1	120	85	6	100	30	140	134	2.4	◎
SGX-36D	PF 1 1/4	145	103	9	125	33	160	161	4.7	◎
SGX-42D	PF 1 1/2	145	103	9	125	40	160	161	4.4	◎
SGX-54D	PF 2	180	127	9	160	50	185	196	8.2	◎
SGX-70D	PF 2 1/2	190	134	9	160	55	192	210	8.7	◎

主材質	鋳鉄
表面処理	電着