

02 耐圧防爆構造クローズアッププラグ

Flameproof Close-up Plug

SBPN-16~54型

d2

工場電気設備防爆指針
(ガス蒸気防爆2006)

Exd II C

技術的基準
(平成8年度版)

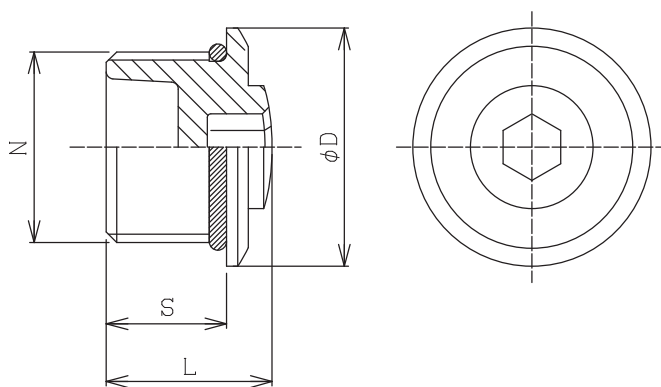

主材質 Material	アルミニウム合金ダイカスト Aluminum Alloy Die-Cast
表面処理 Surface Treatment	ニッケルメッキ Nickel Electroplating

型式 Type	N	φD	S	L	重量(kg) Weight
SBPN-16	PF 1/2	28	16.7	22	0.01
SBPN-22	PF 3/4	33	16.7	23	0.02
SBPN-28	PF 1	40	22	28	0.03
SBPN-36	PF 1-1/4	50	22	29	0.05
SBPN-42	PF 1-1/2	57	22.5	32	0.06
SBPN-54	PF 2	71	25	39	0.11

SMB-70H~104H型

d2

工場電気設備防爆指針
(ガス蒸気防爆2006)

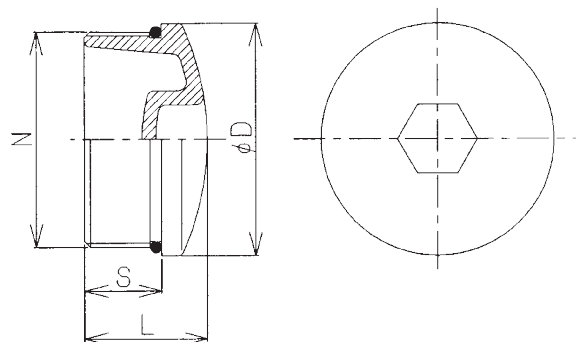

主材質 Material	鋳鉄 Cast Iron
表面処理 Surface Treatment	溶融亜鉛メッキ Hot Dip Galvanized

型式 Type	N	φD	S	L	重量(kg) Weight
SMB-70H	PF 2-1/2	81	27	43	0.57
SMB-82H	PF 3	94	27	43	0.71
SMB-92H	PF 3-1/2	107	30	48	1.04
SMB-104H	PF 4	120	30	48	1.07